

ST500

User Manual

Suntech

Suntech International LTD.



Suntech International Ltd.

1. Introduction

This document describes features, protocols and detail operation of ST500.

If there is another operation description document for special buyer to customize or model and the contents of the document is different with this, customizing document should be applied for special buyer.

2. Overview

Device consists of GPRS, GPS and event parts.

The main purpose of device reports getting GPS position and other informs of vehicle to server periodically.

Device can control or check connected lines and support additional functions.

2-1. Operation Mode

The device has 3 operation modes, driving, parking and emergency.

- ** **Driving** : Driving status when ignition is on.
- ** **Parking** : Parking status that starts if ignition is off during more than T1.
- ** **Emergency** : Once panic button is On or any other status as per designed.
The device sends emergency reports until A1 times or receiving server acknowledge.

2-2. Report

AVL reports GPS and some information at predefined interval, depending on the current modes. Also, AVL sends some alerts, for example, movement at the parking condition, changing of connected input line and so on.

Device distinguishes all reports with 6 types, Status report, emergency, event, alert, alive and command response.

Device can store reports when reporting route (For example, GPRS condition) is not successful. Storage capacity is up to 2,000 status reports, 50 emergency reports, 50 alert reports (include event reports) and 1500 bytes as command response. In case of status reports, oldest report is erased and new report is buffered when the buffer is full and new status report enters (FIFO).

When reporting condition is recovered, device starts sending all buffered reports.

Also, this capacity can increase if it is needed.

Each type of reports has priority, and priority is as below.

Emergency → Command Response → Alert → Status Report → Alive (Lowest)

Emergency is the first to be sent after recovering GPRS condition.

2-3. Setting Parameter

Parameters of device can be changed by GPRS or SMS, and some control can be realized also in the same way.

Detail protocols are described in Chapter 4.

2-4. Features

Key features are described here;

- Power Down

Device can process two steps of power-down, Sleep and Deep Sleep, for reducing power consumption when the vehicle is parked.

- LED Indicator

LED indicates GPRS and GPS states. It's helpful to check error cause.

- Events

Device has 2 output lines, 3 input lines and ignition line.

- Update Firmware by Over The Air (FOTA)

When Firmware of device has some error or has to be changed for a new service to be implemented, device can update internal ROM file by over the air (FOTA), remotely via GPRS. Customers do not need to visit every vehicle to download the new firmware.

Method of FOTA describes at "SunTech_OTA_UA_Protocol" document in detail.

- Parking Lock

Device can check whether the vehicle moves off the preset parking boundary or starts driving without ignition on. In the case that it notes the unauthorized moving or driving, it sends emergency report immediately.

- Over speed

Device can check speed of vehicle and send alert of over-speed to server.

- GPS Antenna Checking

Device can alert when GPS antenna is disconnected.

It's applicable only for models that have external antenna.

- Main Power Checking

The device can recognize the main power and inform to server when main power line is disconnected or main power drops below preset value.

It's applicable only for battery model.

- Battery Error Alert

Device can alert about battery error related on charging.

It's applicable only for battery model.

3. Protocol Construction

All command and reports are string and follows below format.

Every filed is distinguished by semi colon.

All report string from device is ended by '\r' (0x0D).

Command message format (from server to device)

HDR	DEV_ID	VER	Field 1	Field 2	...	Field n
-----	--------	-----	---------	---------	-----	---------

Field	Definitions	Remark
HDR	String	"SA200" + Command type
DEV_ID	6 char.	Device ID of AVL
VER	"02"	Protocol Version. This is fixed with "02".
Field 1 ~ n	String	Contents

Device ID is unique number of each device that consists of 6digits.

If the command has invalid value or DEV_ID of the command that is sent by GPRS or SMS is not matched with DEV_ID of the unit.

Report message format (from device to server)

HDR	DEV_ID	SW_VER	Field 1	Field 2	...	Field n
-----	--------	--------	---------	---------	-----	---------

Field	Definitions	Remark
HDR	String	"SA200" + Report type

DEV_ID	6 char.	Device ID of AVL
VER	"001"	Software version that the device has.
Field 1 ~ n	String	Contents

4. Commands

When the device is received a command, it responds with response string and changes some parameters or acts related operation.

4-1. Network Parameters Setting

HDR	DEV_ID	VER	AUTH	APN	USER_ID	USER_PWD	SEVER_IP	SEVER_PORT
B_SEVER_IP		B_SEVER_IP		SMS_NO	PIN_NO			

● Definition : Set network parameters and PIN number.

Field	Definitions	Unit	Remark
HDR	"SA200NTW"		Command type
DEV_ID	6 char.		Device ID
VER	"02"		Protocol Version
AUTH	'0'/'1'/'A'		GPRS authentication 0 : PAP('NO' in Synctrack) 1 : CHAP('YES' in Synctrack) A : Automatic GPRS set. In this case, parameters in APN, USER_ID and USER_PWD field should be empty.
APN	String		Access Point Name
USER_ID	String		ID for GPRS Access
USER_PWD	String		Password for GPRS Access
SEVER_IP	String		Server IP Address
SEVER_PORT	String		Server Port
B_SEVER_IP	String		Backup Server IP Address
B_SEVER_PORT	String		Backup Server Port
SMS_NO	String		Phone number what the device sends SMS report to. This can be used for backup in the area that if GPRS condition is not good. Or, it can be used main report method when IP and Port are empty.

			For no use, it should be empty.
PIN_NO	String		PIN Number to release PIN lock if it is enabled
<p><example></p> <pre>[command] SA200NTW;850000;02;0;internet;;;111.111.111.111;8600;;;</pre> <pre>[response] SA200NTW;Res;850000;010;0;internet;;; 111.111.111.111;8600;;;</pre> <pre>SA200NTW;Res;850000;010;A1;tim.br;tim;tim; 111.111.111.111;8600;;;</pre>			
<p><notes></p> <p>** If network does not require User ID and Password, these fields should be empty.</p>			
<p>Automatic GPRS Set</p> <p>It the device is set to 'Automatic GPRS Set', the device set GPRS parameters automatically depending on inserted SIM.</p> <p>For example, if Airtel SIM is inserted, the device set AUTH to 0, APN to "aitelgprs.com", USER_ID and USER_PASS to empty.</p> <p>And the device reports response string after adding real GPRS parameters when automatic GPRS set is selected.</p>			

4-2. Report Parameter Setting

HDR	DEV_ID	VER	T1	T2	T3	A1	SND_DIST	T4	SMS_T1	SMS_T2	SMS_PACK_NO
ANGLE_RPT		RPT_TYPE									

- Definition : Set parameters related on report interval.

Field	Definitions	Unit	Remark
HDR	"SA200RPT"		Command type
DEV_ID	6 char.		Device ID
VER	"02"		Protocol Version
T1	String	Sec	Interval for sending status report in parking mode Range : 0 ~ 86400 If 0, report in parking will be sent only one time when vehicle starts parking.
T2	String	Sec	Interval for sending status report in driving mode Range : 0 ~ 60000

			If 0, report in driving will be sent only one time when vehicle starts driving.
T3	String	Sec	Interval for sending status report in emergency mode Range : 0 ~ 9999 If 0, emergency report will be sent only one time when emergency state occurs.
A1	String		Number of attempts for emergency report until the device gets acknowledge from server If 0, no emergency report will be sent.
SND_DIST	String	Meter	Distance interval for sending status report. Range : 0 ~ 60000 (60km) If 0, status report related on moving distance is disabled. If not 0, stats report is send when traveled distance reaches predefined SND_DIST.
T4	String	Sec	Interval for sending keep alive string
SMS_T1	String	Min	Interval for sending status report in parking mode
SMS_T2	String	Min	Interval for sending status report in driving mode
SMS_PACK_NO	String		Report No in one SMS message
ANGLE_RPT	String	Degree	Report STT message if it's greater than ANGLE_RPT. 0 : Disable Range : 1 ~ 179
RPT_TYPE	String		Set the type of reporting. 0: FIFO : First in First Out. 1: LIFO : Last In First Out.
<p><example> [command] SA200RPT;850000;02;180;120;60;3;0;0;0;0;0;0 [response] SA200RPT;Res;850000;010;180;120;60;3;0;0;0;0;0;0</p> <p><notes> ** If report interval is set big number, network may disconnect GPRS connection because GPRS communication is not progressed for a long time. So, unit may not receive command by GPRS. T4 is for protecting against this disconnection by sending short data with short term. ** Alive report can be sent only when the device has no data to send during T4 interval.</p>			

4-3. Event Parameter Setting

HDR	DEV_ID	VER	IGNITION	T1	T2
IN1_TYPE	IN2_TYPE	IN3_TYPE	IN1_CHAT	IN2_CHAT	IN3_CHAT
OUT1_TYPE	OUT2_TYPE	OUT1_ACTIVE	OUT2_ACTIVE		
PULSE1_NO	PULSE1_ON	PULSE1_OFF	PULSE2_NO	PULSE2_ON	PULSE2_OFF
IN4_TYPE	IN5_TYPE	IN4_CHAT	IN5_CHAT	BAUD	

● Definition : Set parameter related event.

Field	Definitions	Unit	Remark
HDR	"SA200EVT"		Command type
DEV_ID	6 char.		Device ID
VER	"02"		Protocol Version
T1	String	Sec	Delay for entering idle mode after ignition goes to off
T2	String	Sec	Delay for entering active mode after ignition goes to on
IN1_TYPE	'0' ~ '7'		0 = Falling Edge 1 = Rising Edge 2 = Both Edge (Falling & Rising) 3 = Panic Button 4 = Call1 Button 5 = Call 2 Button 6 = Reserved 7 = Anti-Theft Button 13 = Disable Immobilizer if it's activated by jammer detector. Default = '3'. Only the device that included voice option (audio circuit) can be set to 'Call1 Button' or 'Call2 Button'.
IN1_CHAT	String	100ms	Input1 chattering time. Range : 0 ~ 9999 Default = 3 sec. If 0, input1 is not checked.

OUT1_TYPE	'0' ~ '5'		<p>0 = GPIO 1 = immobilizer 2 = Immobilizer & Auto active Auto active means immobilizer is activated automatically when the vehicle starts parking. 3 = Pulse 4 = LED Out for indicating call status. Refer 7-2-3. 5 = Buzzer</p>
OUT1_ACTIVE	'0' or '1'		<p>0 = Open when out1 is active 1 = GND when out1 is active</p>
PULSE1_NO	String		<p>Pulse number when out1 type set to pulse. Range : 0 ~ 9999 If pulse no is 9999, pulsing runs permanently.</p>
PULSE1_ON	String	100ms	<p>Active time of pulse1 Range : 0 ~ 9999 It should be set with even number.</p>
PULSE1_OFF	String	100ms	<p>Inactive time of pulse1 Range : 0 ~ 9999 It should be set with even number.</p>
BAUD	'0' ~ '4'		<p>It's available when extra events support RS232. Baud-rate 0 = No use 1 = 4800bps 2 = 9600bps 3 = 19200bps 4 = 38400bps 5 = 115200bps If the device does not support RS232, it should be 0.</p>

<example>

[command] SA200EVT;850000;02;1;60;0;3;2;2;30;20;20;1;0;1;0;0;0;0;0;0;0;0;0

[response] SA200EVT;Res;850000;010;1;60;0;3;2;2;30;20;20;1;0;1;0;0;0;0;0;0;0;0;0

<notes>

** If IGNITION is set to '0', device doesn't check driving or parking state of the vehicle. It reports status string with idle mode always, and cannot support parking lock and the service that enters sleep or deep sleep automatically when the vehicle is parked.

** If IGNITION is set to '2', the device checks driving or parking state of the vehicle with voltage range of vehicle's battery. We named it as 'Virtual Ignition'. Virtual ignition can operate when the device installed into real vehicle and it may be need adjustment of voltage range for special vehicle. For setting method, please refer 6.3.

** In case of pulse, pulse time may have tolerance about dozens of ms.

** Immobilizer, LED Blink line and Buzzer type cannot set both OUT1 and OUT2 simultaneously.

** In case that a event is set to "door sensor", active state means door is opened.

** If device has the Handsfree kit, each time the volume up button is pressed once, the speaker volume is turned up as below.

0 -> 1 -> 2 -> 3 -> 4 ->5 ->0 -> 1 -> 2 ->3 -> 4 -> 5 -> 0 -> 1 ->

(0 : Volume mute, 5 :Max Volume)

Type of no supported event line is fixed to "No Use".

Below table is for example of 4 line event model.

Field	Definitions	Unit	Remark
HDR	"SA200EVT"		Command type
DEV_ID	6 char.		Device ID
VER	"02"		Protocol Version
IGNITION	'0' ~ '2'		Ignition using state 0 : Not use ignition 1 : Use ignition Line 2 : Virtual ignition(power) 3 : Virtual ignition (motion)
T1	String	Sec	Delay for entering idle mode after ignition goes to off
T2	String	Sec	Delay for entering active mode after ignition goes to on

IN1_TYPE	'0' ~ '5'		<p>0 = Falling Edge 1 = Rising Edge 2 = Both Edge (Falling & Rising) 3 = Panic Button 4 = Call1 Button 5 = Call 2 Button 6 = Reserved 7 = Anti-Theft Button 13 = Disable Immobilizer if it's activated by jammer detector. Default = '3'. Only the device that included voice option (audio circuit) can be set to 'Call1 Button' or 'Call2 Button'.</p>
IN1_CHAT	String	100ms	<p>Input1 chattering time. Range : 0 ~ 9999 Default = 3 sec. If 0, input1 is not checked.</p>
OUT1_TYPE	'7'		7 = No Use
OUT1_ACTIVE	'0' or '1'		
PULSE1_NO	'0'		
PULSE1_ON	'0'		
PULSE1_OFF	'0'		
BAUD	'0'		0 = No use
<p><example> [command] SA200EVT;850000;02;1;60;0;3;2;2;30;20;20;1;0;1;0;0;0;0;0;0;0;0;0;0;0;0 [response] SA200EVT;Res;850000;010;1;60;0;3;8;8;30;0;0;6;6;1;0;0;0;0;0;0;0;8;8;0;0;0 <notes> ** In case of event 4 line model, IN2_TYPE, IN3_TYPE, IN4_TYPE, IN5_TYPE, OUT1_TYPE and OUT2_TYPE should be 'No Use'. Type and chat time of non used event lines are set to 'No Use' and '0' automatically although these filed of command is set to other value.</p>			

4-4. GSM Parameter Setting

HDR	DEV_ID	VER	SMS_LOCK	SMS_MT1	SMS_MT2	SMS_MT3
-----	--------	-----	----------	---------	---------	---------

HDR	DEV_ID	VER	PARKING_LOCK	SPEED_LIMIT	PWR_DN	CON_TYPE
ZIP	GROUP_SEND	MP_CHK	ANT_CHK	BAT_CHK	M_SENSOR	CALL
GEO_FENCE	DATA_LOG	ANTITHFT_CNT1	ANTITHFT_CNT2	JAM_DET		
JAM_CHK_DIST	JAM_CHK_TM					

● Definition : Set parameters related report.

Field	Definitions	Unit	Remark
HDR	"SA200SVC"		Command type
DEV_ID	6 char.		Device ID
VER	"02"		Protocol Version
PARKING_LOCK	'0' or '1'		Parking lock enable (1) / disable (0) If 1, the device checks vehicle position in parking periodically. When the vehicle goes off some boundary or starts moving over some velocity, the device reports parking lock emergency.
SPEED_LIMIT	String	Km/h	Over speed limit If 0, the device does not check over speed. If 1 and the vehicle runs over predefined value, device reports speed alerts once.
PWR_DN	'0' ~ '2'		Power saving type 0 : Disabled sleep and deep sleep service 1 : Enabled deep sleep 2 : Enabled sleep
CON_TYPE	'0' ~ '2'		Connection Type with Server 0 = KEEP_CON 1 = KEEP_DISCON 2 = KEEP_NOP Detail explanation is below.
ZIP	'0' or '1'		Use Zip Disable (0) / Enable (1)
GROUP_SEND	'0' or '1'		Group Send for stored data 0 : Disable 1 : Enable. One packet can include up to 5 reports. Group send is explained below.

MP_CHK	'0' or '1'		Main Power Disconnection Check Disable (0) / Enable (1)																																				
ANT_CHK	'0' or '1'		GPS Antenna Connection Error Check Disable (0) / Enable (1)																																				
BAT_CHK	'0' or '1'		Backup Battery Error Check Disable (0) / Enable (1)																																				
M_SENSOR	'0' ~ '4'		<p>Motion Sensor</p> <table border="1"> <thead> <tr> <th></th> <th>Motion</th> <th>Collision</th> <th>Shock</th> </tr> </thead> <tbody> <tr> <td>0</td> <td>Disable</td> <td>Disable</td> <td>Disable</td> </tr> <tr> <td>1</td> <td>Enable</td> <td>Disable</td> <td>Disable</td> </tr> <tr> <td>2</td> <td>Disable</td> <td>Disable</td> <td>Enable</td> </tr> <tr> <td>3</td> <td>Enable</td> <td>Disable</td> <td>Enable</td> </tr> <tr> <td>4</td> <td>Disable</td> <td>Enable</td> <td>Disable</td> </tr> <tr> <td>5</td> <td>Enable</td> <td>Enable</td> <td>Disable</td> </tr> <tr> <td>6</td> <td>Disable</td> <td>Enable</td> <td>Enable</td> </tr> <tr> <td>7</td> <td>Enable</td> <td>Enable</td> <td>Enable</td> </tr> </tbody> </table>		Motion	Collision	Shock	0	Disable	Disable	Disable	1	Enable	Disable	Disable	2	Disable	Disable	Enable	3	Enable	Disable	Enable	4	Disable	Enable	Disable	5	Enable	Enable	Disable	6	Disable	Enable	Enable	7	Enable	Enable	Enable
	Motion	Collision	Shock																																				
0	Disable	Disable	Disable																																				
1	Enable	Disable	Disable																																				
2	Disable	Disable	Enable																																				
3	Enable	Disable	Enable																																				
4	Disable	Enable	Disable																																				
5	Enable	Enable	Disable																																				
6	Disable	Enable	Enable																																				
7	Enable	Enable	Enable																																				
CALL	'0' or '1'		Support Call with headset Disable (0) / Enable (1)																																				
GEO_FENCE	'0' or '1'		Support Geo-fence Disable (0) / Enable (1)																																				
DAT_LOG	'0' or '1'		Log out with RS232 0 = No Use 1 = Enable getting saved log data by RS232																																				

<example>

[command] SA200SVC;850000;02;1;120;0;0;0;0;1;1;1;0;0;0;0;0;0;0

[response] SA200SVC;Res;850000;010;1;120;0;0;0;0;1;1;1;0;0;0;0;0;0;0

<notes>

** Function of M_SEMSOR can be used with the model that has motion sensor.

If shock or collision detection is enabled, device will report to server when gets any shock or collision.

** If this parameter has been customized, This table should be disregarded and you should follow customized operation document.

CON_TYPE

1. KEEP_CON : The device keeps TCP connection always and can receives a command by GPRS.
2. KEEP_DISCON : The device connects TCP connection when the data is sent. After sending, the device disconnects GPRS and TCP connection if it estimates there is no data for sending within

3minutes. In this case, it cannot receive a command by GPRS.

- KEEP_NOP : The device doesn't send any report after be installed. When the device enters emergency mode or receive 'Start Report' command by SMS or RS232, it starts report depending on report parameters. It may be used for saving GPRS fee. Current version cannot support this option.

Group Send

The device stores data if the vehicle is in no GPRS area. And, the vehicle moves to GPRS available area, device starts sending stored data.

If group send option is enabled, the device makes 5 reports to one bundle and send these 5 reports at one time.

Group send is useful to speed up sending.

M_Sensor

- Collision: The device sending a event when ignition is ON and have a motion.
- Shock: The device sending a event when ignition is OFF and have a motion.

Jamming detection procedure

JAM_CHK_DIST & JAM_CHK_TM are assist for jamming detection to avoid false detection.

At least, we recommend use JAM_CHK_DIST for safety.

If you use two assist functions, it can detect two case of jamming as follows.

*Case of jamming GPRS only.

Jamming detected -> JAM_CHK_DIST -> JAM_CHK_TM -> Triggered by JAM_DET mode.

*Case of jamming GPRS & GPS.

Jamming detected -> JAM_CHK_TM -> Triggered by JAM_DET mode.

JAM_CHK_DIST : if 0, skip this function.

JAM_CHK_TM : if 0, skip this function.

If disable all of assist functions, just triggered by HAM_DET mode after detected jamming.

In this case, it's possible to false detection in weak GSM or strong radio area.

4-6. Additional Parameters

HDR	DEV_ID	VER	SVR_TYPE	B_SVR_TYPE	UDP_ACK	DEV_PORT
-----	--------	-----	----------	------------	---------	----------

- Definition : Setting additional parameter requested.

Field	Definitions	Unit	Remark
HDR	"SA200ADP"		Command type
DEV_ID	6 char.		Device ID
VER	"02"		Protocol Version
SVR_TYPE	'T' / 'U'		Server Protocol Type T : TCP U : UDP
B_SVR_TYPE	'T' / 'U'		Backup Server Protocol Type T : TCP U : UDP
UDP_ACK	'0' ~ '3'		ACK from Server when UPD is used. 0 : No use 1 : ACK when the server receives reports except alive. 2 : ACK when the server receives reports except STT and alive report. 3 : ACK when the server receives emergency report. Command response doesn't need ACK.
DEV_PORT	String		Device's port for receiving command from UDP server. It can be used only when UDP server is used. If '0' or empty, the device would use port 9000. If not zero, the device can receive commands with port DEV_PORT.
Reserved	'0'		
Reserved	'0'		
Reserved	'0'		
Reserved	'0'		
Reserved	'0'		
Reserved	'0'		
<p><example> [command] SA200ADP;850000;02;U;T;2;9000;0;0;0;0;0 [response] SA200ADP;Res;850000;022;U;T;2;9000;0;0;0;0;0 <notes> This command can be applied from software version 22.</p>			
<p>ACK in case of UDP</p>			

UDP is protocol that doesn't check whether the data is transmitted successfully. So, the device checks completion of sending with ACK depending on UDP_ACK type.

ACK is sent by server when the data is received.

If the ACK is not sent during more than 2 minutes after sending, the device recognizes the data was not reached to server and sends the data again.

Examples of ACK report are as below.

String Format : "SA200ACK;850000"

Zip Format : 0x15 0x85 0x00 0x00

It is recommended ACK_TYPE is set to '1' to confirm all data can be transmitted safely.

Report Type	UDP_ACK=0	UDP_ACK=1	UDP_ACK=2	UDP_ACK=3
Alive	X	X	X	X
STT	X	O	X	X
Event, Alert, Etc.	X	O	O	X
Emergency	X	O	O	O

4-7. Set Parameters of Main Voltage

HDR	DEV_ID	VER	CHR_STOP_THRES_12	CHR_STOP_THRES_24	DECIDE_BAT_24
OPERATION_STOP_THRES_12			OPERATION_STOP_THRES_24	IGNDET_H	IGNDET_L

- Definition : Set some value of main voltage.

Field	Definitions	Remark
HDR	"SA200MBV"	Command type
DEV_ID	6 char.	Device ID
VER	"02"	Protocol Version

CHR_STOP_THRES_12	String	Voltage value to stop backup battery charging in 12V vehicle.
DECIDE_BAT_24	String	Voltage value to check whether the vehicle's battery is 12V.
OPERATION_STOP_THRES_12	String	Voltage value to protect vehicle battery. The device operation stops if car battery voltage is lower than this value in vehicle that has 12V power.
IGNDET_H	String	In case of virtual ignition, the vehicle can recognize driving state when vehicle power is more than IGNDET_H. Default = '0'
IGNDET_L	String	In case of virtual ignition, the vehicle can recognize parking state when vehicle power is less than IGNDET_L. Default = '0'
<p><example> [command] SA200MBV;850000;02;10.5;22;19;8.00;18.00;0;0 [response] SA200MBV;Res;850000;122;10.5;22;19;8.00;18.00;0;0</p> <p><note> IGNDET_H and IGNDET_L are '0', device check parking and driving automatically.</p>		

4-8. Set Parameters of Motion Sensor

HDR	DEV_ID	VER	CHR_STOP_THRES_12	CHR_STOP_THRES_24	DECIDE_BAT_24
OPERATION_STOP_THRES_12		OPERATION_STOP_THRES_24		IGNDET_H	IGNDET_L
VI_ON_THRES		VI_ON_DELAY	VI_ON_PERCENT		VI_OFF_THRES
VI_OFF_DELAY		VI_OFF_PERCENT			

● Definition : Set motion sensor parameters

Field	Definitions	Unit	Remark
HDR	"SA200MSR"		Command type
DEV_ID	6 char.		Device ID
VER	"02"		Protocol Version
SHOCK_DELAY	String	Sec.	Delay for entering shock detection mode after ignition off 0 – Disable

			Range : 1 ~ 21600 (5hour) Recommend : 600 (10 min.)
MOTION_THRES	String	Step	Detection level of shock violation. Range : 0.04 ~ 2.0 Recommend : 0.04
SHOCK_THRES	String	Step	Detection level of shock violation. Range : 0.04 ~ 2.0 Recommend : 0.04
COLL_THRES	String	Step	Gravity for collision report. Range : 0.1 ~ 2.0 Recommend : 0.7
VI_ON_THRES	String	1/255G	Threshold value for Motion Virtual Ignition On Range : 3~50 Default : 5
VI_ON_DELAY	String	Sec.	Delay time for Motion Virtual Ignition On Range : 3~999 Default : 10
VI_ON_PERCENT	String	%	Percent for Motion Virtual Ignition On. Range : 30~100 Default: 70
VI_OFF_THRES	String	1/255G	Threshold value for Motion Virtual Ignition Off Range : 3~50 Default : 5
VI_OFF_DELAY	String	Sec.	Delay time for Motion Virtual Ignition Off Range : 3~999 Default : 10
VI_OFF_PERCENT	String	%	Percent for Motion virtual Ignition Off. Range : 30 ~ 100 Default : 70
<p><example> [command] SA200MSR;;02;600;0.04;0.04;0.7;5;10;70;5;10;70 [response] SA200MSR;Res;852588;128;600;0.04;0.04;0.70;5;10;70;5;10;70</p> <p><notes> * For the shock level, we recommend it to set to 0.04. if it's over than 0.04, the sensor will be more insensitive as it for shock detection.</p>			

4-11. Control Command

HDR	DEV_ID	VER	CMD_ID
-----	--------	-----	--------

- Definition : Controls some functions.

Field	Definitions	Unit	Remark
HDR	"SA200CMD"		Command type
DEV_ID	6 char.		Device ID
VER	'01'		Protocol Version
CMD_ID	String		Control command content

Caution : If it's not correct the Unit ID, ignored.

4-11-1. Status Request

- Definition : Location poll, request of the status report.

Field	Definitions	Unit	Remark
CMD_ID	"StatusReq"		Status request If received, the device sends status string instantly.
<p><example> <example> [command] SA200CMD;850000;02;StatusReq [response] SA200STT;850000;010;20090724;07:12:16;00129;+37.479995;+126.885815;000.029;000.00;7;1;0;15.33;100000;2;0002</p>			

4-11-2. Reset

- Definition : Reset all of parameters.

Field	Definitions	Unit	Remark
CMD_ID	"Reset"		Reset

1 = Enable	1 = Enable	1 = Sleep 2 = Deep sleep	disconnected. 1 = Backup battery is connected.
------------	------------	-----------------------------	---

Field	Definitions	Unit	Remark
CMD_ID	"PresetA"		Report all parameters including additional parameter.

<example>

[command] SA200CMD;850000;02;PresetA

[response] SA200CMD;Res;850000;010;PresetA;

NTW;0;internet;;111.111.111.111;8600;;1234;

RPT;60;180;120;60;3;0;0;;

EVT;1;60;0;3;2;2;30;20;20;1;1;1;0;0;0;0;0;0;0;0;0;0;

GSM;0;;0;;

SVC;1;120;0;0;0;0;1;1;1;0;0;0;0;

ADP;U;T;2;9000;0;0;0;0;0;0;

DEV;0;0;0;0;0;0;0;

<notes>

**** This command can be applied from software version 22.**

** DEV filed informs current status of device as below.

OUT1 0 = Disable 1 = Enable	OUT2 0 = Disable 1 = Enable	PWR_DN 0 = Normal 1 = Sleep 2 = Deep sleep	BAT_CON 0 = Backup battery is disconnected. 1 = Backup battery is connected.
-----------------------------------	-----------------------------------	---	--

TRACKING 0 = Stop Tracking 1 = Start Tracking	Anti-Theft 0 = Disable 1 = Enable	Reserved	Reserved
---	---	----------	----------

4-11-4. ACK of Emergency

- Definition : Stop emergency report.

Field	Definitions	Unit	Remark
CMD_ID	"AckEmerg"		Acknowledgement of emergency report. The device will stop emergency reports if it is in emergency state.
<p><example> [command] SA200CMD;850000;02;AckEmerg [response] SA200CMD;Res;850000;010;AckEmerg</p>			

4-11-5. Enable1

- Definition : Active Output1.

Field	Definitions	Unit	Remark
CMD_ID	"Enable1"		Enable Output1
<p><example> [command] SA200CMD;850000;02;Enable1 [response] SA200CMD;Res;850000;010;Enable1 [response] SA200CMD;Res;850000;010;Enable1NoUse (in case that IN type is set to 'No Use').</p> <p><notes> ** Output1 line goes to active status. ** If OUT1 set with immobilizer, output1 line goes to active status gradually with pulse in driving mode. ** If OUT1 set with pulse type, output1 line generates pulse and returns inactive state after pulsing out automatically.</p>			

4-11-6. Disable1

- Definition : Inactive Output1.

Field	Definitions	Unit	Remark
CMD_ID	"Disable1"		Disable Output1
<p><example> [command] SA200CMD;850000;02;Disable1</p>			

[response] SA200CMD;Res;850000;010;Disable1
 [response] SA200CMD;Res;850000;010;Disable1NoUse (in case that IN type is set to 'No Use').

<notes>

** Output1 line goes to inactive status.

4-11-9. Request IMSI

- Definition : Request the unique SIM ID.

Field	Definitions	Unit	Remark
CMD_ID	"ReqIMSI"		Request IMSI (unique SIM ID) If received, device sends IMSI of using SIM.
<example>			
[command] SA200CMD;850000;02;ReqIMSI			
[response] SA200CMD;Res;850000;010;ReqIMSI;724031111553779			

4-11-10. Request ICCID

- Definition : Request the ICCID.

Field	Definitions	Unit	Remark
CMD_ID	"ReqICCID"		Request ICCID (sequence number that is displayed on SIM) If received, device sends ICCID of using SIM.
<example>			
[command] SA200CMD;850000;02;ReqICCID			
[response] SA200CMD;Res;850000;010;ReqICCID;89550230000084256668			

4-11-11. ReqVer

- Definition : Request software version.

Field	Definitions	Unit	Remark
CMD_ID	"ReqVer"		Request device version Device reports Model, Buyer, Protocol and S/W release version.

<example>

[command] SA200CMD;850000;02;ReqVer

[response] SA200CMD;Res;850000;010;ReqVer;SA200E_SAMPLE_STBASE_001

4-11-12. Erase All

- Definition : Erase all of data in buffer.

Field	Definitions	Unit	Remark
CMD_ID	"EraseAll"		Erase saved all reports and disable outputs. This is needed to initialize just before device is delivered to a customer.

<example>

[command] SA200CMD;850000;02;EraseAll

[response] SA200CMD;Res;850000;010;EraseAll

4-11-13. Initialize Traveled Distance

- Definition : Initialize the travel distance.

Field	Definitions	Unit	Remark
CMD_ID	"InitDist"		Set traveled distance to 0.

<example>

[command] SA200CMD;850000;02;InitDist

[response] SA200CMD;Res;850000;010;InitDist

4-11-14. Initialize Message Number

- Definition : Initialize the message sequence number.

Field	Definitions	Unit	Remark
CMD_ID	"InitMsgNo"		Set message number to 0.

<example>

[command] SA200CMD;850000;02;InitMsgNo

[response] SA200CMD;Res;850000;010;InitMsgNo

4-11-23. Reboot

- Definition : reboot unit.

Field	Definitions	Unit	Remark
CMD_ID	"Reboot"		Reboot device.

<example>

[command] SA200CMD;850000;02;Reboot

[response] SA200CMD;Res;850000;010;Reboot

4-11-24. Request SIM IP Address

- Definition : Request of the local IP address in SIM card.

Field	Definitions	Unit	Remark
CMD_ID	"ReqSIMIP"		SIM card IP request

<example>

[command] SA200CMD;850000;02;ReqSIMIP

[response] SA200CMD;Res;850000;010;ReqSIMIP;172.16.18.6

3. Installation

3.1 Insert SIM card.

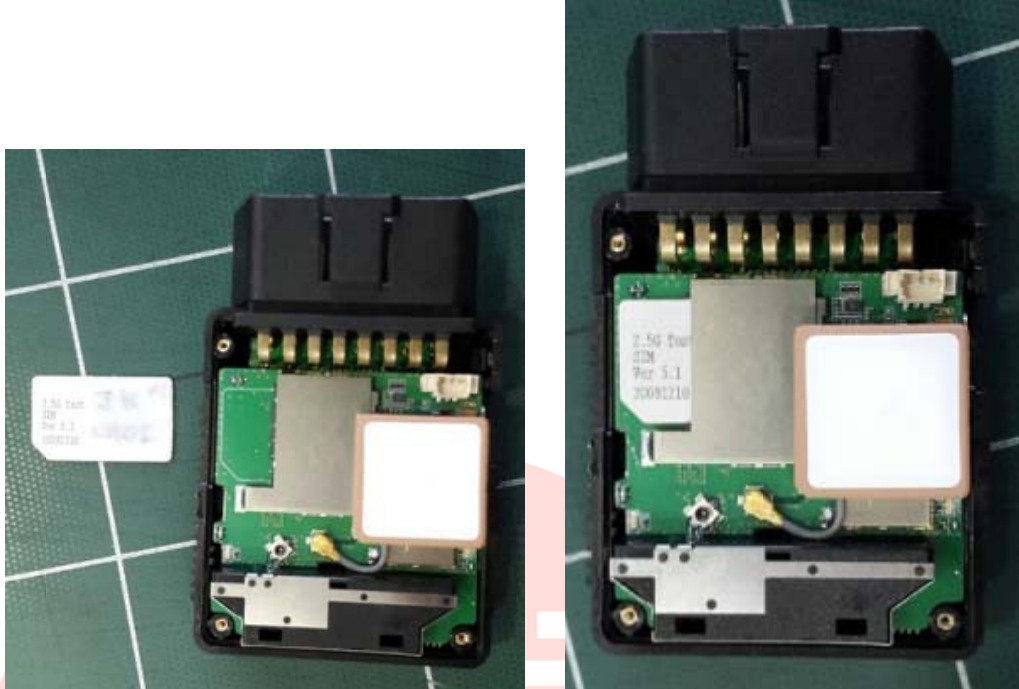



Suntech

Suntech International LTD.

4. Trouble Shooting (LED Indicator)

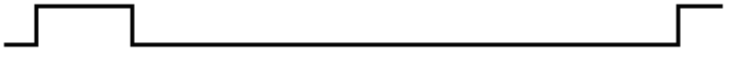
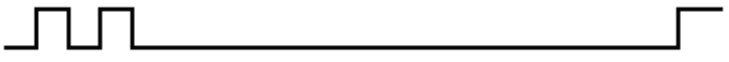
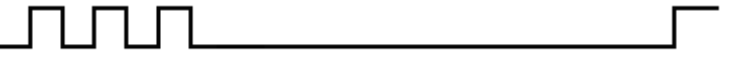
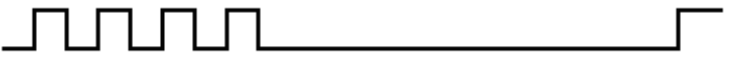
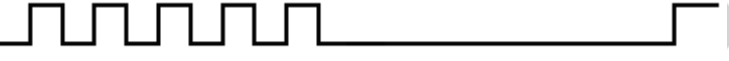
4.1 Blue LED: Indicates GPRS status.

GPRS	Blink Count	Remarks
Normal	1	
Server Com. Error	2	 <p><Possible Cause></p> <ol style="list-style-type: none"> 1. Server or network parameter is wrong. 2. Server is closed. 3. Temporary network barrier
GPRS Com. Error	3	 <p><Possible Cause></p> <ol style="list-style-type: none"> 1. Network parameter is wrong. 2. SIM is blocked about GPRS using. 3. Temporary network barrier 4. Weak GPRS signal 5. GPRS antenna connection is not firm.
No Network	4	 <p><Possible Cause></p> <ol style="list-style-type: none"> 1. GPRS antenna is disconnected. 2. GPRS antenna or socket of GPRS antenna is broken. 3. Device is broken.
SIM PIN Locked	5	 <p><Possible Cause></p> <ol style="list-style-type: none"> 1. SIM PIN is enabled.
Cannot Attach NW	6	 <p><Possible Cause></p> <ol style="list-style-type: none"> 1. Weak GPRS signal. 2. GPRS antenna connection is not firm.
No SIM	7	 <p><Possible Cause></p> <ol style="list-style-type: none"> 1. There is no SIM or SIM is not inserted properly. 2. SIM or SIM socket is broken.

4.2 RED LED: Indicates GPS status.

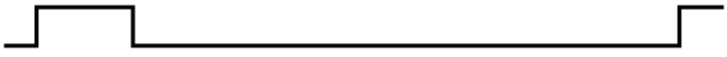
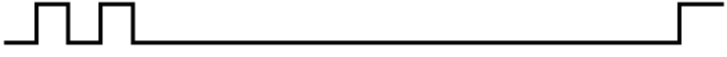
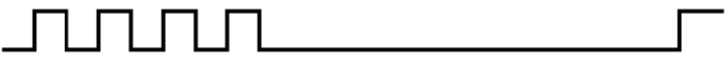
GPS	Blink Count	Remarks
Normal	1	
No Fix	2	 <p><Possible Cause></p> <ol style="list-style-type: none"> 1. If power on, GPS chipset is trying to find position during some minutes. 2. GPS antenna lays on weak or no GPS signal position 3. GPS antenna connection is not firm.
GPS Chipset Error GPS Antenna Error	4	 <p><Possible Cause></p> <ol style="list-style-type: none"> 1. GPS antenna is disconnected. 2. GPS antenna or socket of GPS antenna is broken. 3. Unit is broken.



FCC Information to User

This equipment has been tested and found to comply with the limits for a Class B digital device, pursuant to part 15 of the FCC Rules. These limits are designed to provide reasonable protection against harmful interference in a residential installation. This equipment generates uses and can radiate radio frequency energy and, if not installed and used in accordance with the instructions, may cause harmful interference to radio communications. However, there is no guarantee that interference will not occur in a particular installation. If this equipment does cause harmful interference to radio or television reception, which can be determined by turning the equipment off and on, the user is encouraged to try to correct the interference by one or more of the following measures:

- Reorient or relocate the receiving antenna.
- Increase the separation between the equipment and receiver.
- Connect the equipment into an outlet on a circuit different from that to which the receiver is connected.
- Consult the dealer or an experienced radio/TV technician for help.

This device complies with part 15 of the FCC Rules. Operation is subject to the condition that this device does not cause harmful interference.

Any changes or modifications not expressly approved by the party responsible for compliance could void the user's authority to operate this equipment.

IMPORTANT NOTE:

FCC RF Radiation Exposure Statement:

This equipment complies with FCC radiation exposure limits set forth for an uncontrolled environment. This equipment should be installed and operated with minimum distance 20cm between the radiator & your body.

This transmitter must not be co-located or operating in conjunction with any other antenna or transmitter.